

EQUIPMENT LIST

ITEM	DESCRIPTION	QTY
A	20' INFEEED CONVEYOR	2
B	AIC TIPPER ACCUMULATOR SYSTEM	1
C	HYDRAULIC POWER UNIT	1
E	TX STACKER PALLET STACKER	4
F	10' OUTFEED CONVEYOR	4
G	6' SAFETY BARRIER	5
H	SKATE CONVEYOR	1
I	135 DEGREE CURVED TAPERED ROLLER GRAVITY CONVEYOR:	1
J	CONTROL CABINET	1
K	10' SAFETY BARRIER	1

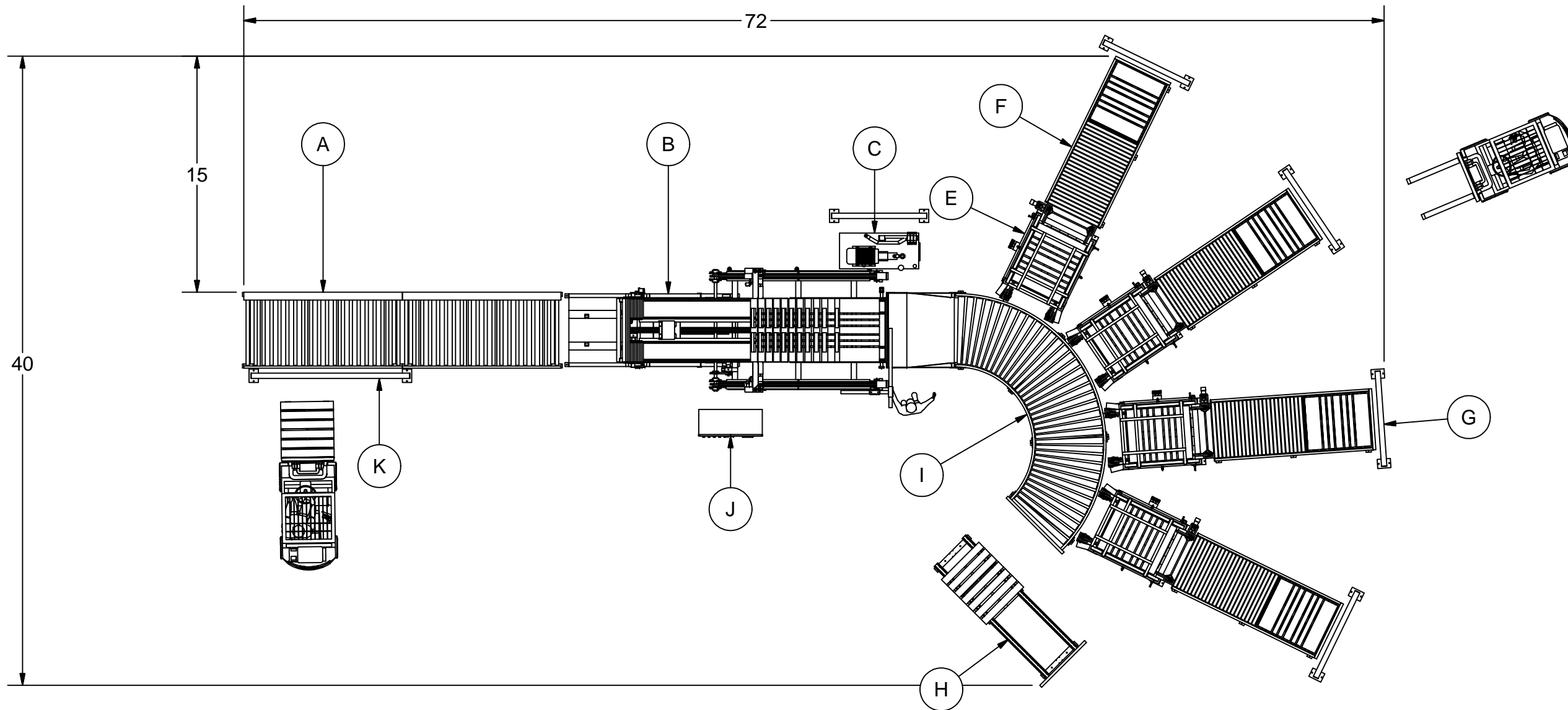
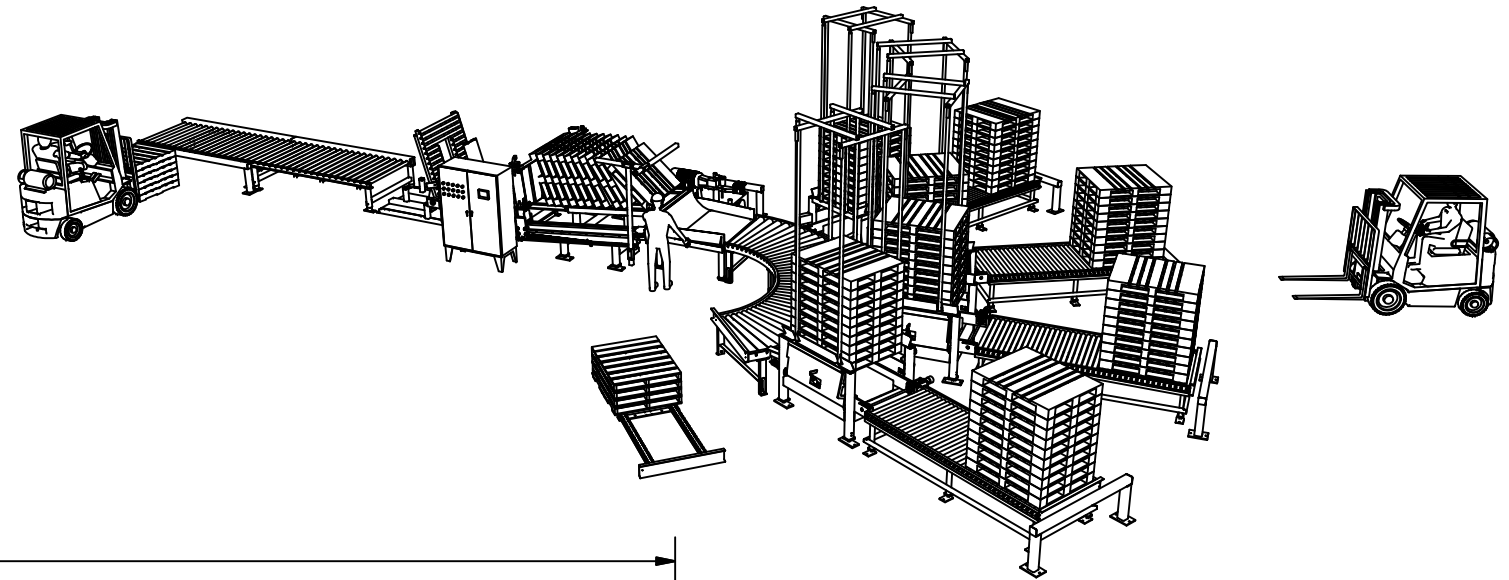

PROPERTY OF PALLET REPAIR SYSTEMS INC. JACKSONVILLE IL AND IS LOANED TO THE RECIPIENT SUBJECT TO RETURN UPON DEMAND. IT'S CONTENTS ARE CONFIDENTIAL AND MUST NOT BE COPIED OR SUBMITTED TO OUTSIDE PARTIES FOR USE OR EXAMINATION.

UNLESS OTHERWISE SPECIFIED
 DIM TOLERANCE: INCHES
 ONE PLACE: +/- .10
 TWO PLACES: +/- .050
 ANGLES: +/- 1
 () INDICATES REF DIM

QTY: 1
 MODEL:
 NEXT ASSY:

MATERIAL: LOSIFRA	SCALE: NTS
DRAWN BY: TDL	DATE: 3-30-17
DESCP: SORT LINE	
SHEET NO: 1 OF 1	PART NO: LOS-2017-01
	REV: A